

CATALOGUE

910064CC

**Electronic Thermostatic
Mixing Valve User Manual**

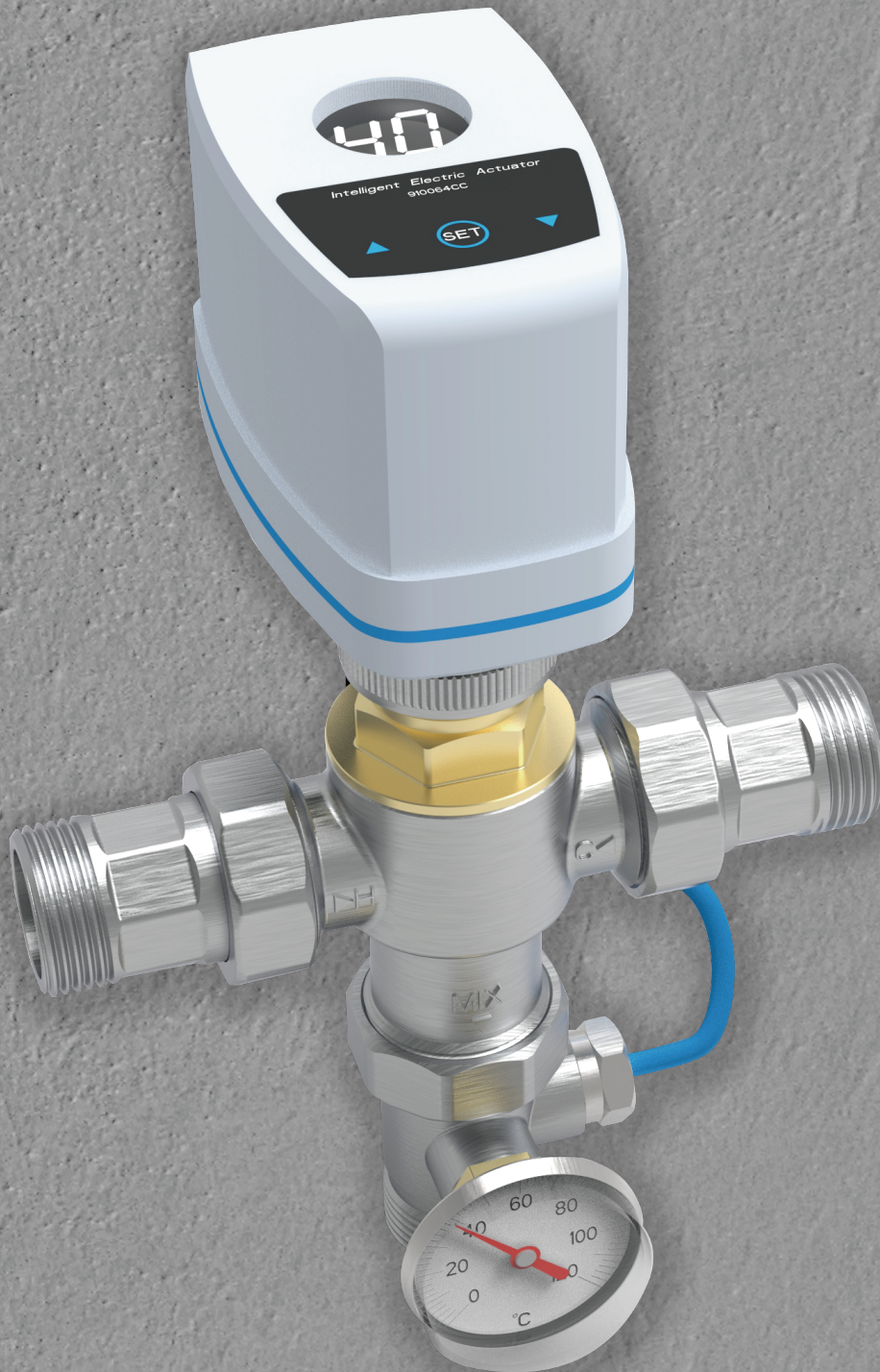

Please read this manual carefully before installation and use.

Please keep this instruction manual in good condition for reference when necessary. If there is any change in the information of this specification, the company shall retain the final interpretation right of this specification without notice.

1. Working principle

Electronic thermostatic mixing valve combines the functions of mechanical thermostatic mixing valve and the management efficiency of electric actuator. Mechanical thermostatic mixing valve can quickly react to the changes of inlet temperature, pressure and flow rate, and quickly recover the set temperature of mixed water. The electric actuator performs further program management on the mechanical thermostatic mixing valve by sensing the outlet temperature of the mixed water to correct the outlet temperature.

The electric actuator can intuitively display the current outlet water temperature of the mixed water. The remote temperature control of mixed water can be realized by replacing the electric actuator with networking function.

2. Structural characteristics

- ① Integrated Electric Actuator
- ② Control buttons and LCD display
- ③ Valve body
- ④ Temperature Sensor
- ⑤ Thermometer

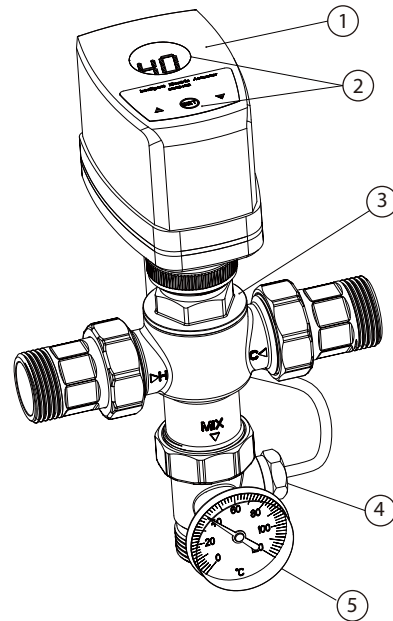

3. Feature

- ✓ Pressure-resistant temperature fluctuation
- ✓ Water-break safety and anti-scalding
- ✓ Anti-scaling and anti-wear
- ✓ Liquid crystal display of mixed water outlet temperature
- ✓ Networkable remote control (optional)

4. Technical parameter

Valve body materials	Brass	Mixing Temperature range	30℃ ~ 50℃	Accuracy	±2.0℃
Maximum static pressure	10bar	Maximum dynamic pressure	5bar	Minimum dynamic pressure	0.5bar
hot water inlet temperature	60℃ ~ 65℃	Cold water inlet temperature	10℃ ~ 15℃	Voltage	DC24V

5. Dimensions

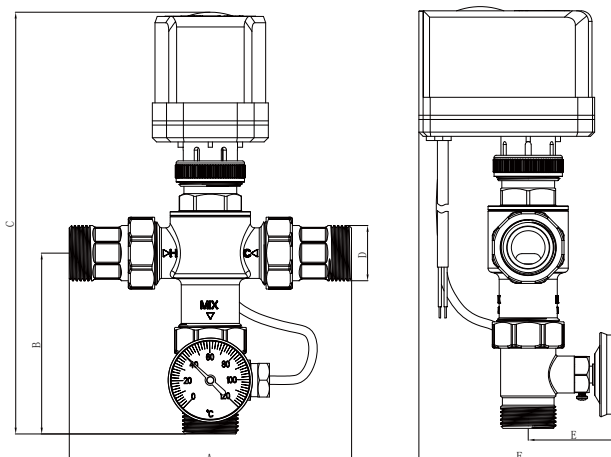

Model	A	B	C	D	E	F
910064CC	134mm	86mm	200mm	G3/4"	44mm	96mm
910064CC-A (Networking)	134mm	86mm	200mm	G3/4"	44mm	96mm

6. Instructions

6.1 Temperature setting description

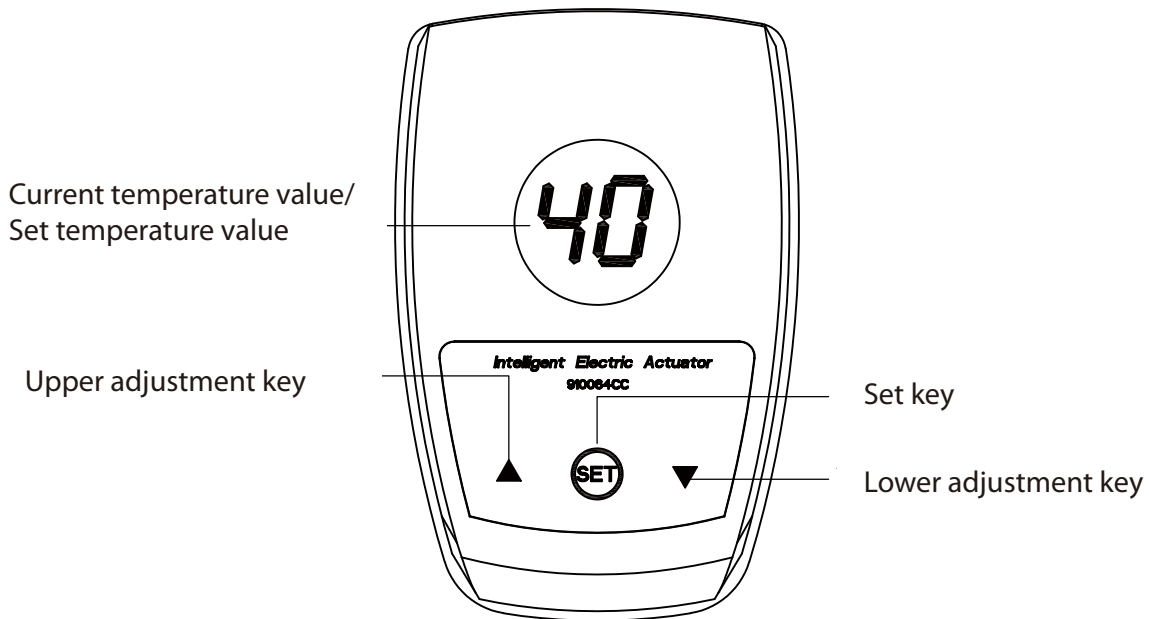

Set temperature: Press and hold the 'set key' for 3-5 seconds, the temperature of the LCD starts to jump at the current set temperature. Then press the 'upper adjustment key' or 'lower adjustment key' to adjust the set temperature value. After adjusting it, confirm the set temperature value after 15 seconds without operation.

Check temperature: By observing the liquid crystal display value (non-jump state), namely the current mixed water outlet temperature value.

6.2 Installation

- ① First, calculate the total water consumption per hour and the characteristics of the hot and cold water sources according to the water consumption of all water-using equipment, and select a mixing valve of appropriate specifications. If the flow of a single valve cannot meet the demand, multiple valves can be used in parallel.
- ② According to the assembly diagram, connect the thermostatic mixing valve and cut-off valve and other facilities. The cold and hot water inlets of the thermostatic mixing valve are equipped with check valves, filters, loose joint and other pipe fittings for maintenance and repairs when the water is stopped. Correctly connect hot and cold water inlet pipe interface : marked with ' H ' inlet end connected hot water inlet ; marked ' C ' inlet end connected with cold water inlet
- ③ After the installation is completed and checked, the water supply debugging can be carried out. When the temperature and pressure of cold and hot water meet the requirements, the water supply equipment is open, and the electric actuator is adjusted until the outlet temperature is suitable.
- ④ To ensure the normal use of thermostatic mixing valve the minimum mixed water flow value. When the actual flow rate is lower than this flow rate, the outlet water temperature will be significantly reduced and unstable. The minimum flow rate of thermostatic mixing valve is 1/20 of measured flow rate.
- ⚠ ⑤ Make sure that the integrated electric actuator, temperature sensor and temperature meter are installed in place before using water and electricity. Do not remove the integrated electric actuator and use it alone!

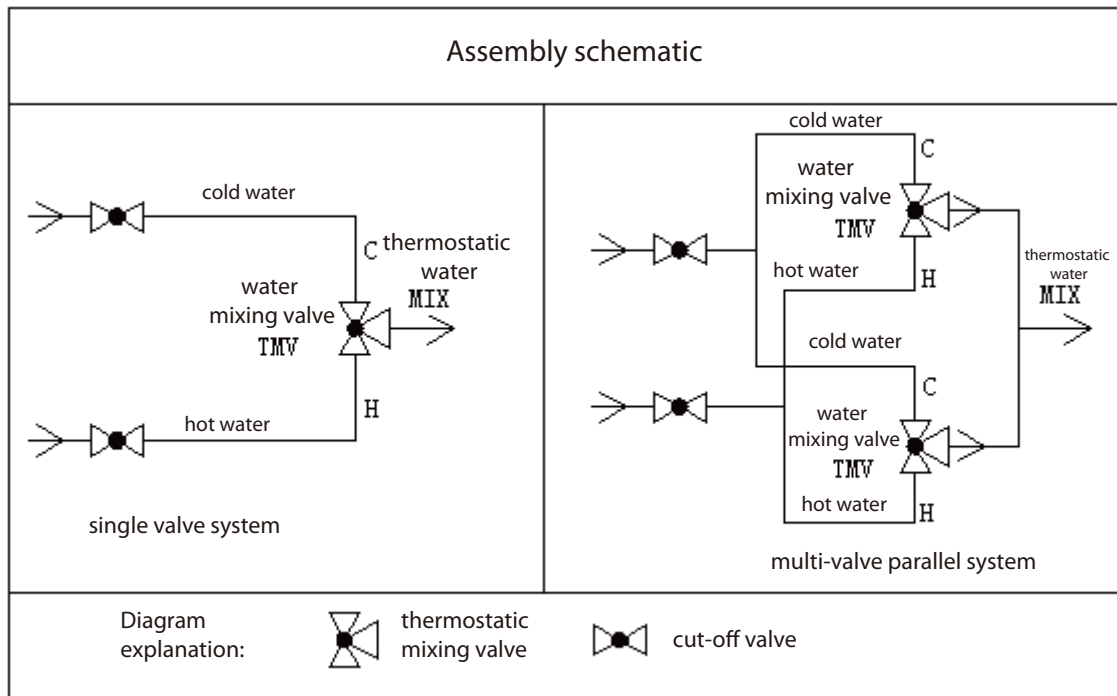

7. Notes

- 7.1 Before installing the thermostatic mixing valve, the pipeline must be thoroughly cleaned to remove sundries.
- 7.2 According to the cold and hot water identification on the valve body: 'H' is hot water, 'C' is cold water, access to cold and hot water correctly.
- 7.3 When testing the water, please ensure that the cold and hot water are supplied normally at the same time, and the temperature and pressure are within the normal working range of the thermostatic mixing valve.
- 7.4 When adjusting the temperature, ensure that the water outlet is normal, and slowly adjust the set temperature of the electric actuator until the outlet water temperature is suitable.
- 7.5 The factory commissioning conditions are hot water temperature 65°C, cold water temperature 15°C, cold and hot water pressure 3bar. Since the actual water temperature and water pressure are different, the outlet temperature may deviate from the set value, which is a normal phenomenon.
- 7.6 The power supply connecting the electric actuator should be waterproof and away from the water source.